

SCHEDA TECNICA / FICHE TECHNIQUE / PRODUKT-DATENBLATT / TECHNICAL SPECIFICATIONS

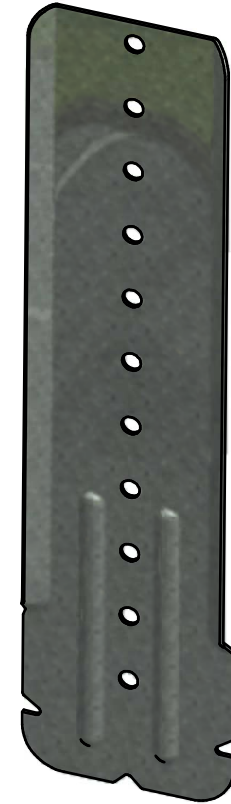
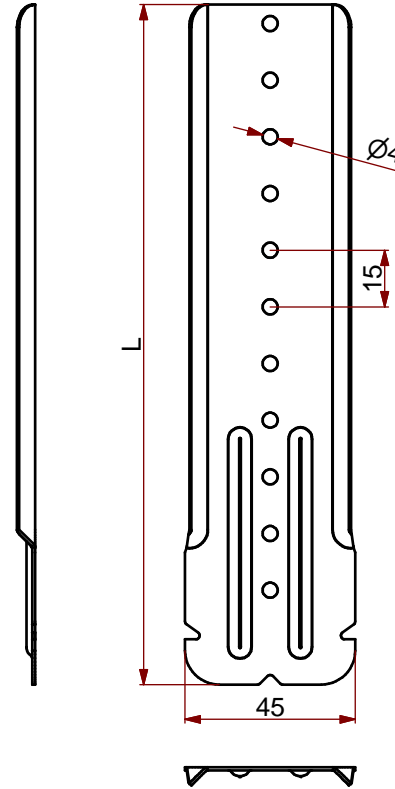
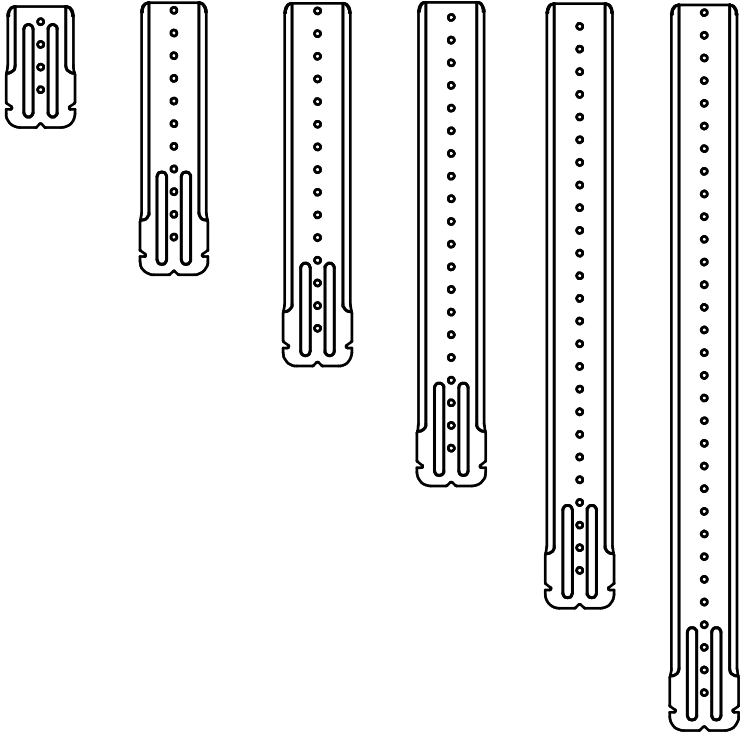

DIMENSIONI / DIMENSIONS / DIMENSIONS / ABMESSUNGEN

Articolo / Article / Article / Artikel	F.203	F.204	F.205	F.206	F.207	F.208
Lunghezza L / Longueur L / Length L / Länge L	80mm	180mm	240mm	320mm	400mm	480mm

IMPIEGO EMPLOI ANWENDUNG USE	Controsoffitti Cartongesso Faux plafonds en plaque de plâtre Gipskartondecken Plasterboard false ceilings
NORMA DI RIFERIMENTO NORME DE REFERENCE NORM STANDARD REGULATION	DIN EN 13964 E DIN18168 DIN EN 13964 ET DIN18168 DIN EN 13964 UND DIN18168 DIN EN 13964 AND DIN18168
MATERIALE MATERIEL MATERIALART MATERIAL	Acciaio zincato tipo DX51D secondo UNI EN 10346 tolleranze secondo UNI EN 10143 Acier galvanise type DX51D selon UNI EN 10346 tolerance selon UNI EN 10143 Verzinktes Stahlblech der Sorte DX51D nach DIN EN 10346 nach den Toleranzen UNI EN 10143 Galvanized steel DX51D type according to UNI EN 10346 tolerances according to UNI EN 10143
RESISTENZA A FLESSIONE RESISTENCE A LA FLEXION BIEGESTEIFIGKEIT BENDING STREIGHT	Carico di snervamento >280N/mm2 Charge d'enervement > 280N/mm2 Fließgrenze > 280 N/mm2 Yield point > 280 N/mm2
RESISTENZA CORROSIONE RÉSISTANCE CORROSION KORROSIONSSCHUTZ CORROSION RESISTANCE	Corrosione Standard secondo EN 13964 Classe B Corrosion standard selon EN 13964 Classe B Korrosionsstandard nach EN 13964 Klasse B Standard corrosion according to EN 13964 class B

CIPRIANI PROFILATI

CIPRIANI PROFILATI s.r.l. - Via Pineta, 31 - 38068 Rovereto (TN) Italy
P. Iva 01173470228 - Tel. +39 0464 421412 - Fax. +39 0464 431330
E-mail: info@ciprianiprofilati.it - Web: www.ciprianiprofilati.it

Disegnato/ Dessiné/ Gedehnt/ Drawn: G. Carbonari
 Controllato/ Contrôlé/ Kontrolliert/ Checked: P. Vivaldelli
 Approvato/ Approuvé/ Bewährt/ Approved: G. Cipriani

Disegno/ Schème/ Zeichnung/ Drawing:

F.203

Scala/ Echelle/ Abschlus/ Scale:

1:1 1:2 1:5



Data/ Date/ Daten/ Date:

02/10/2012

Unità di misura/ Unité de mesure/ Maßeinheit/ Unit of measurement:

mm



SINCERT
 QUALITY SYSTEM
 CERTIFIED
 UNI EN ISO 9001
 SGS n. IT 07/1415

CIPRIANI PROFILATI s.r.l. - Ogni diritto sul contenuto del presente disegno è riservato al sistema di certificazione SGS. La sua riproduzione, totale o parziale, (in cui, a titolo esemplificativo, è fornito l'esempio), (testi, immagini, disegni grafici) sono espressamente vietati in assenza di autorizzazione scritta dal proprietario del presente disegno. CIPRIANI PROFILATI s.r.l. - All rights reserved on the contents of the present technical drawings are reserved according to the law in force. Their total or partial reproduction, publication and distribution (including by way of an example, the tests, the images, the graphic drawings) are explicitly forbidden without the written authorization of the above mentioned company.